

Bomba autocebante plástica blindada

- 5104 Bomba de 1/3 HP con trampa de pelo (BA35)
- 5105 Bomba de 1/2 HP con trampa de pelo (BA50)
- 5106 Bomba de 3/4 HP con trampa de pelo (BA75)
- 5107 Bomba de 1 HP con trampa de pelo (BA100)
- 1102 Bomba monoblock sin motor

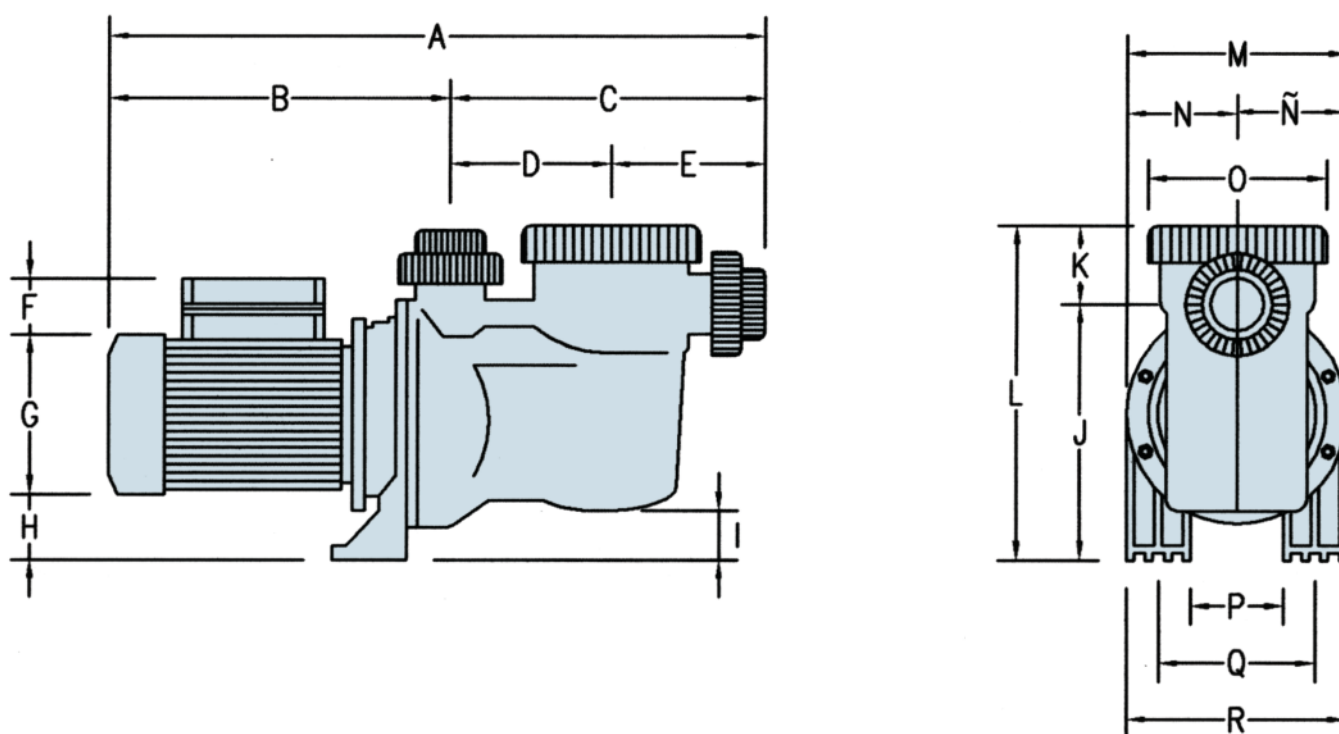

MODELO	CAUDAL (m3/h)											
	0	2	4	6	8	10	12	14	16	18	20	22
	ALTURA MANOMÉTRICA (m.c.a.)											
BA 35	12,80	12,50	11,50	9,60	6,70	3,20						
BA 50	13,50	13,00	12,40	11,00	9,00	6,00	2,70					
BA 75	14,00	13,70	13,30	12,50	11,20	9,60	7,60	5,30	2,80			
BA 100	14,80	14,30	14,00	13,30	12,20	10,80	9,40	7,50	5,40	2,80		
BA 150	15,40	15,20	15,00	14,20	13,70	12,40	11,60	9,50	7,70	5,40	3,10	0,00

MODELO	BOCAS		MEDIDAS GENERALES EN mm																		
	Asp.	Imp.	A	B	C	D	E	F	G	H	I	J	K	L	M	N	Ñ	O	P	Q	R
BA 35	1 1/2"	1 1/2"	555	280	260	135	125	70	130	36	24	198	72	270	196	98	98	135	99	144	169
BA 50	1 1/2"	1 1/2"	555	280	260	135	125	70	130	36	24	198	72	270	196	98	98	135	99	144	169
BA 75	1 1/2"	1 1/2"	555	280	260	135	125	70	130	36	24	198	72	270	196	98	98	135	99	144	169
BA 100	1 1/2"	1 1/2"	555	280	260	135	125	70	130	36	24	198	72	270	196	98	98	135	99	144	169
BA 150	1 1/2"	1 1/2"	555	280	260	135	125	70	130	36	24	198	72	270	196	98	98	135	99	144	169